

Features:

- Minimal external leakage.
- Galvanized Steel
- Construction standard. (other materials available upon request)
- Blade stop to prevent slide from inadvertently being pulled out or slipping in certain orientations.
- 60° blade angle reduces
- Possibility of material build-up on blade.
- Improved air flow based on angled gate orientation.
- Cannot be completely closed. Minimizes the possibility of duct work collapse due to high vacuum levels.

Industries:

Textiles, paper, tobacco, wood, plastics, agricultural & rubber dust applications.

Available Services:

- System Integration
- Industrial Ventilation
- Material Handling
- Power & Controls
- Manufacturing

Product Description:

ATMOS360'S Balancing slide gates are used in Dust Control Systems to ensure each collection point is receiving the proper air flow for optimal efficiency. The clean design minimizes fouling of the gate when used in converting or other web handling applications where large pieces of broken web can be entrained in the air flow.

Benefits:

- Application: Air & dust collection systems.
- Sizes: 2" thru 28" Diameter.
- Optional clean out doors are available for sizes 8" and above.
- Heavy duty construction



BALANCE SLIDE GATE

**64 CIRCLE FREEWAY DR
CINCINNATI, OH 45246
www.atmos360.com
Phone: 513-330-5442
E-mail: info@atmos360.com**

Balance Slide Gate Models & Size

MODEL	SIZE DIAMETER
500320	2"
500306	3"
500292	4"
500278	5"
500166	6"
500144	7"
500239	8"
500228	9"
500001	10"
500012	11"
500023	12"
500034	13"
500045	14"
500056	15"
500067	16"
500078	17"
500089	18"
500100	19"
500111	20"
500122	21"
500133	22"
500345	23"
500155	24"
500359	25"
500177	26"
500188	27"
500267	28"

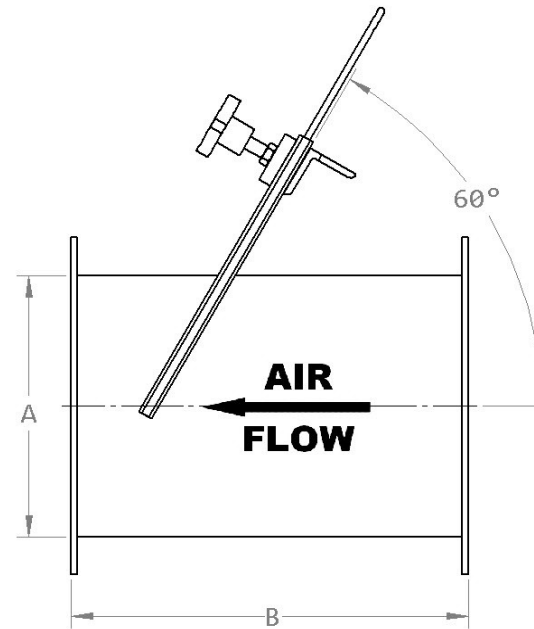

Duct Size (A)	B
3" to 8"	9"
9" to 18"	15"
20" to 30"	18"

ATMOS360, Inc
 64 Circle Freeway Dr
 Cincinnati, OH 45246
 Phone: (513) 330-5442